

Direct Mount Ceiling Suspension System

decoustics®

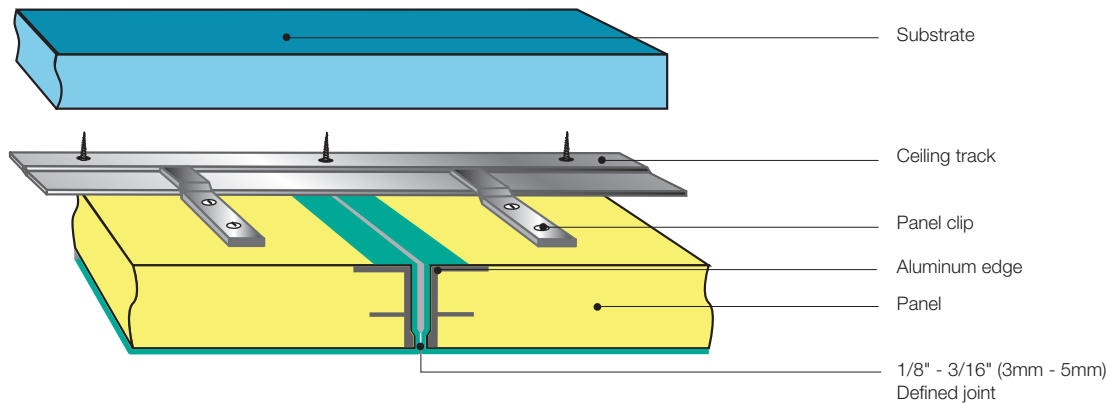

DESIGN AND SPECIFICATIONS

Description

Decoustics Direct Mount is an acoustical panel ceiling system. Panels are installed using a mechanical z-clip (slide and engage) method of fastening directly to a firm substrate such as gypsum board, concrete, steel deck, wood or a similar surface.

Panels

All Decoustics panels are custom fabricated and offered in a variety of types, sizes, geometric shapes, ellipses, vaults, acoustical domes, thicknesses and finishes. Standard thickness tolerance is $\pm 1/32"$ (1mm).

Limitations

Essentially non-accessible. Progressive removal of panels is necessary.

For curved applications (i.e. barrel vault), a factory precurved channel is strongly recommended to ensure panel alignment.

Design Considerations

A 1" (25mm) wide perimeter reveal is required around all ceiling areas to facilitate installation of the z-clips. Alternatively the reveal can be covered with an exposed, crown or cornice type moulding.

Lights, diffusers, speakers, smoke detectors, sprinklers, and similar items that penetrate or are located in the ceiling must be independently supported. The panel is not structurally capable of supporting the weight of any of these items.

When using speakers in ceiling or wall panels, it is recommended the speaker grille be visibly mounted at the face of the panel. Speaker function creates air movement and any fabric covering the speaker will experience premature soiling.

Maintenance

Refer to appropriate Decoustics "Cleaning and Maintenance Instructions" for any specific finish.

Standards, Tests and Approvals

Surface Burning Characteristics (ASTM E-84 and CAN ULC S102): All panel components have a Flame Spread rating of less than 25.

Note: Building code requirements may necessitate composite panel testing based on specified finish.

A panel comprised of "Class A" (Flame Spread of 25 or less) components does not necessarily produce a composite panel meeting the "Class A" requirement. Decoustics has a considerable number of composite panel tests on file.

Mounting Methods

Mechanically mount only, direct to substrate. Install panels flat and level to $\pm 1/16"$ (1.5mm) over an 8'-0" (2440mm) length. Shim continuous ceiling track if necessary to obtain flat level ceiling. Install continuous ceiling track runners at starter, intermediate and finisher locations. Fit slide and engage z-clips (mounted on back of panels) into ceiling track runners or onto adjacent panels, depending on panel type, size and layout.

Where possible, secure panels or mounting hardware to a substrate support such as metal furring or stud framing.

Allow for 1" (25mm) wide reveal around perimeter of each ceiling area.

To prevent building vibration from dislocating panels, install locking pins, outboard clips or similar devices at perimeter locations. Refer to manufacturers shop drawings and installation instructions.

Decoustics Direct Mount Ceiling Suspension System

Performance Data

FINISH	EDGE OPTIONS	SIZES	CONSTRUCTION	THICKNESS	NRC	WEIGHT	COLOR
Fabric	Resin: - square - bevelled - radiused - stepped - available Reveal joint Butt joint. (specific fabrics only) Aluminum: square edge with 1/8" - 3/16" (3mm - 5mm) defined joint; or bevelled edge.	Fabric: Up to 60" x 120" (1525mm x 3050mm). Finish width must be sufficient to cover panel, panel thickness, and wrap minimum 1" (25mm) on back side.	Panel consists of a 6 to 7 pcf (96 to 112 kg/m ³) core. Fabric corners are fully tailored (no exposed darting). A 1 mil clear vapor barrier is adhered to panel back.	1" (25mm) 2" (50mm)	0.85 1.10	0.88 psf (4.30 kg/m ²) 1.51 psf (7.37 kg/m ²)	As per finish selected.
Claro or Metallo	Aluminum: Coated square edge with 1/8" - 3/16" (3mm - 5mm) defined joint.	Recommended: Up to 72" x 48" (1830 mm x 1220mm). Handling larger panels may result in damage to panels. Consult Decoustics for larger panel sizes.	Panel consists of a 6 to 7 pcf (96 to 112 kg/m ³) density acoustically absorptive core, with a special high acoustic performance layer laminated to face (1-1/16" (27mm) overall thickness) designed to receive a non-bridging acoustically transparent coating. A 1 mil clear vapor barrier is adhered to panel back.	1-1/16" (27mm)	0.85	1.05 psf (5.15 kg/m ²)	Claro Light Reflectance 90% Custom colors to match color chips
Quadrillo	Unfinished square kerf and spline, 3/32" (2.4mm) edge banding veneer and solid wood face frame. Custom edge profiling on request. Refer to Finishes section for additional acoustical data.	48" x 60" (1220mm x 1525mm).	Panel consists of a 6 to 7 pcf (96 to 112 kg/m ³) density mat faced core laminated between a layer of 1/4" (6mm) thick Quadrillo face and a 1/8" (3mm) HDF perforated backing board (QPP). Internal fire treated particle board framing as required for edge conditions.	QPP-19 1-1/8" (28mm) QPP-25 1-3/8" (35mm) QPP-50 2-3/8" (60mm)	0.70 0.80 1.00	2.80 psf (13.68 kg/m ²) 3.40 psf (16.61 kg/m ²) 5.5 psf (26.85 kg/m ²)	Anigre Ash Beech Cherry Mahogany Maple Oak Paint Finish Pear Walnut
Solo-M	Unfinished square kerf and spline, 3/32" (2.4mm) edge banding veneer and solid wood face frame. Custom edge profiling on request.	36" x 60" (915mm x 1525mm)	Panel consists of a perforated NAUF, ribbed, fire rated medium density fiberboard (MDF) core with a natural wood veneer laminated to the face	5/8" (16mm)	0.65	2.00 psf (9.75 kg/m ²)	Custom veneers available on request

PRECAUTIONS: Failure to install panels flat and level will void any warranty, and can result in over-stressing of panel clips and eventual panel disengagement.

Note: The information provided in this Data Sheet is accurate to the best of our knowledge at the time of printing. However, we reserve the right to make changes when necessary without further notification. Suggested applications may need to be modified to conform with local building codes and conditions. We cannot accept responsibility for products that are not used, or installed, to our specifications. Please refer to our website for most current data.

Note: Only handle panels wearing clean, lightweight, white gloves during installation. Follow manufacturer's printed instructions for installation as well as field cutting of panels.

Acoustical Data (ASTM C423: Type F5 Mounting as per ASTM E795).

FINISH	PANEL THICKNESS	FREQUENCY (Hz)						NRC	SAA
		125	250	500	1000	2000	4000		
Fabric	1" (25mm)	0.35	0.41	0.84	1.09	1.09	1.02	0.85	0.84
Fabric	2" (50mm)	0.19	0.87	1.20	1.19	1.08	1.03	1.10	1.05
Claro or Metallo	1-1/16" (27mm)	0.17	0.36	1.04	1.01	1.05	1.01	0.85	0.87
Quadrillo QPP-19	Panel 1-1/8" (28mm) Core 3/4" (19mm)	0.05	0.16	0.59	1.01	0.94	0.69	0.70	0.69
Quadrillo QPP-25	Panel 1-3/8" (35mm) Core 1" (25mm)	0.07	0.28	0.85	1.09	0.95	0.74	0.80	0.79
Quadrillo QPP-50	Panel 2-3/8" (60mm) Core 2" (50mm)	0.29	0.82	1.18	1.06	1.00	0.73	1.00	1.03

Acoustic testing was performed on a panel finished with an acoustically transparent fabric.